

Summit 11000/12000 Probe Station



This guide contains information to help prepare your facility for the arrival of your FormFactor probe station.



NOTE

Facility requirements for thermal systems are listed separately. See the Facility Planning Guide specific to your thermal system for details.

Probe Station Requirements

Clean Dry Air (CDA)	General use	<ul style="list-style-type: none"> • ISO 8573.1 Class 1.4.1 (3°C dew point, oil less than 0.01 mg/m³) • 110 l/min (3.9 CFM) at SATP* supplied at 6-8 bar (87 - 116 psi) gage • 8 mm OD push-in tube connection (3 m max tube length)
	MicroChamber probing environment	<ul style="list-style-type: none"> • ISO 8573.1 Class 1.1.1 (-70°C dew point, oil less than 0.01 mg/m³) • Max flow: quick purge up to 280 l/min (9.9 CFM) at SATP* supplied at 6-8 bar (87 - 116 psi) gage • Continuous flow: 57-85 l/min (2-3 CFM) at SATP* supplied at 6-8 bar (87 - 116 psi) gage • 10 mm OD push-in tube connection (3 m max tube length)
	MicroChamber probing environment and general use CDA	<ul style="list-style-type: none"> • ISO 8573.1 Class 1.1.1 (-70°C dew point, oil less than 0.01 mg/m³) • Max flow: quick purge and platen jets up to 330 l/min (11.7 CFM) at SATP* supplied at 6-8 bar (87 - 116 psi) gage • Continuous flow: 57-85 l/min (2-3 CFM) at SATP* supplied at 6-8 bar (87 - 116 psi) gage • 10mm OD push-in tube connection (3 m max tube length) • Chamber atmospheric pressure dew point: <ul style="list-style-type: none"> – Thermal system operated down to +20°C: ≤ -45°C at SATP* (-29°C at 5 bar [73 psi] gage) – Thermal system operated down to -40°C: ≤ -50°C at SATP* (-35°C at 5 bar [73 psi] gage) – Thermal system operated down to -60°C: ≤ -70°C at SATP* (-57°C at 5 bar [73 psi] gage) <p>CDA for general use may be supplied by the MicroChamber supply for a single service supply.</p>
	<p> WARNING</p> <p>FormFactor does not endorse or recommend using nitrogen instead of CDA for thermal system operation with any FormFactor system due to the risk of oxygen depletion in the working environment.</p> <p>If your testing configuration requires the use of nitrogen instead of CDA for MicroChamber purge, time in Quick Purge mode should be controlled. Discuss your setup with your safety and facilities departments to ensure that the oxygen flow in your working environment is adequate to dissipate any nitrogen build up. The use of oxygen sensor alarms is also recommended.</p> <p> NOTE</p> <p>Note that the combined values for independent general use and MicroChamber purge flow are not equal to the value for simultaneous general use and MicroChamber purge flow.</p> <p>Modification of the manifold plumbing is required if you are using N₂. See the Summit User Guide for details.</p>	
Vacuum	<ul style="list-style-type: none"> • Wafer hold on chuck and positioners: <ul style="list-style-type: none"> – Required: < 500 mbar (14.8 inHg) absolute, -510 mbar (-15.0 inHg) gage, at up to 3.4 l/min (0.12 CFM) at SATP* – Recommended: < 400 mbar (11.8 inHg) absolute, -610 mbar (-18.0 inHg) gage, at up to 5 l/min (0.18 CFM) at SATP* – 8 mm OD push-in tube connection (3 m max tube length) • Wafer hold only (while under test to ensure measurement performance): <p>Vacuum pressure stability: ± 10 mbar (0.3 inHg)</p>	

Summit 11000/12000 Probe Station

Power	Probe station	<ul style="list-style-type: none"> • Single phase: 100-127 VAC or 208-240 VAC 50/60 Hz • 460 VA • Source: <ul style="list-style-type: none"> – North America: NEMA 5-20 for 100-127 VAC or NEMA L6-15 for 208-240 VAC – Europe: CEE VII (Schuko) – Other: consult factory • Appropriate international power cables will be supplied. 	
	Circuit breaker	Minimum rating: 10,000 AIC	
	Accessories	<ul style="list-style-type: none"> • Vacuum pump 1 A / 0.5 A • Air compressor 3 A / 1.5 A • Video camera 0.5 A / 0.25 A • Laser 6 A / 3 A • Laser illuminator 3 A / 1.5 A • Microscope illuminator 2.5 A / 1.25 A • Computer 1.5A / 0.75A typical • Computer monitor 1.5A / 0.75A typical 	
Thermal Systems	Refer to the facility preparation guide for your thermal system.		
Environmental Conditions	Operating	<ul style="list-style-type: none"> • Altitude up to 2000 m • Main supply voltage fluctuations not to exceed $\pm 10\%$ of the nominal voltage • A total current of 3.2/1.6 A, 115/230 VAC is required for both auxiliary and microscope outlets. The combined leakage current of accessories attached to these two outlets must be less than 3mA. 	
	Ambient temperature	• +18°C to +28°C	
	Relative humidity	• 20% to 60%	
	Ambient vibration (including floor)	<p>The probe station should be used with a Cascade Microtech recommended vibration isolation table. The vibration isolation table is intended for use in an environment having background vibrations at or below the ISO Operating Theatre level:</p> <ul style="list-style-type: none"> • Maximum level 4000 micro-in./sec (72 dB), measured using the 1/3-octave-band velocity spectra method 	
	Seismic restraints	Installation of seismic restraints is required to safely restrain the probe station during a seismic event and to meet the safety requirements as outlined by SEMI-S2.	
Additional Equipment	Workbench	<ul style="list-style-type: none"> • Size: minimum 1200 wide x 760 mm deep (47 x 30 in.) • Capacity: 230 kg (507 pounds) minimum 	
	Flowmeter	<ul style="list-style-type: none"> • 0-4 SCFM air flow with quick purge bypass (standard on Summit -AP and -M MicroChamber stations, optional and ordered separately for Summit -S stations) • The flowmeter is not required if an air dryer is included in the system configuration. • If a MicroChamber is included in the system configuration, a flowmeter is included for purge air control. Specifications for the flowmeter are 0-4 SCFM air flow with quick purge bypass. 	
Dimensions	Probe station	• See Dimensions on page 3.	
	Clearance	Front	• 800 mm (32 in.) for operator/installation during installation or service
		Back	<ul style="list-style-type: none"> • 1000 mm (39 in.) for service access • 800 mm (32 in.) when using optional holders for monitor, keyboard or test instrument
		Left/right	<ul style="list-style-type: none"> • 200 mm (8 in.) for cables, maximum 450 mm (17.7 in.) for use of control console • 800 mm (32 in.) during installation or service, or permanently when using optional holders for monitor, keyboard or test instrument
		Top	• 400 mm (16 in.)
Additional clearance may be required for thermal system cooling units.			

Summit 11000/12000 Probe Station

Weight	Probe station	• ~182 kg (401 pounds)
	Lifting requirements	To avoid personal injury and/or damage to the station, a forklift (minimum 400-pound capacity) is required to move the unit, and a minimum of four to six people will be required to shift it onto the table. Note that the weight is not distributed evenly between all four corners of the station. The rear of the station is heavier than the front.
Shipping Dimensions (WxDxH)	Probe station crate (with table)	• 1050 x 1170 x 1010 mm (42 x 46 x 40 inches)
Shipping Weight	Probe station and crate	• ~272 kg (600 pounds)

* Standard Ambient Temperature And Pressure (SATP)

Dimensions



NOTE

Refer to [Clearance](#) on page 2 for recommended working space around the station.

Front View

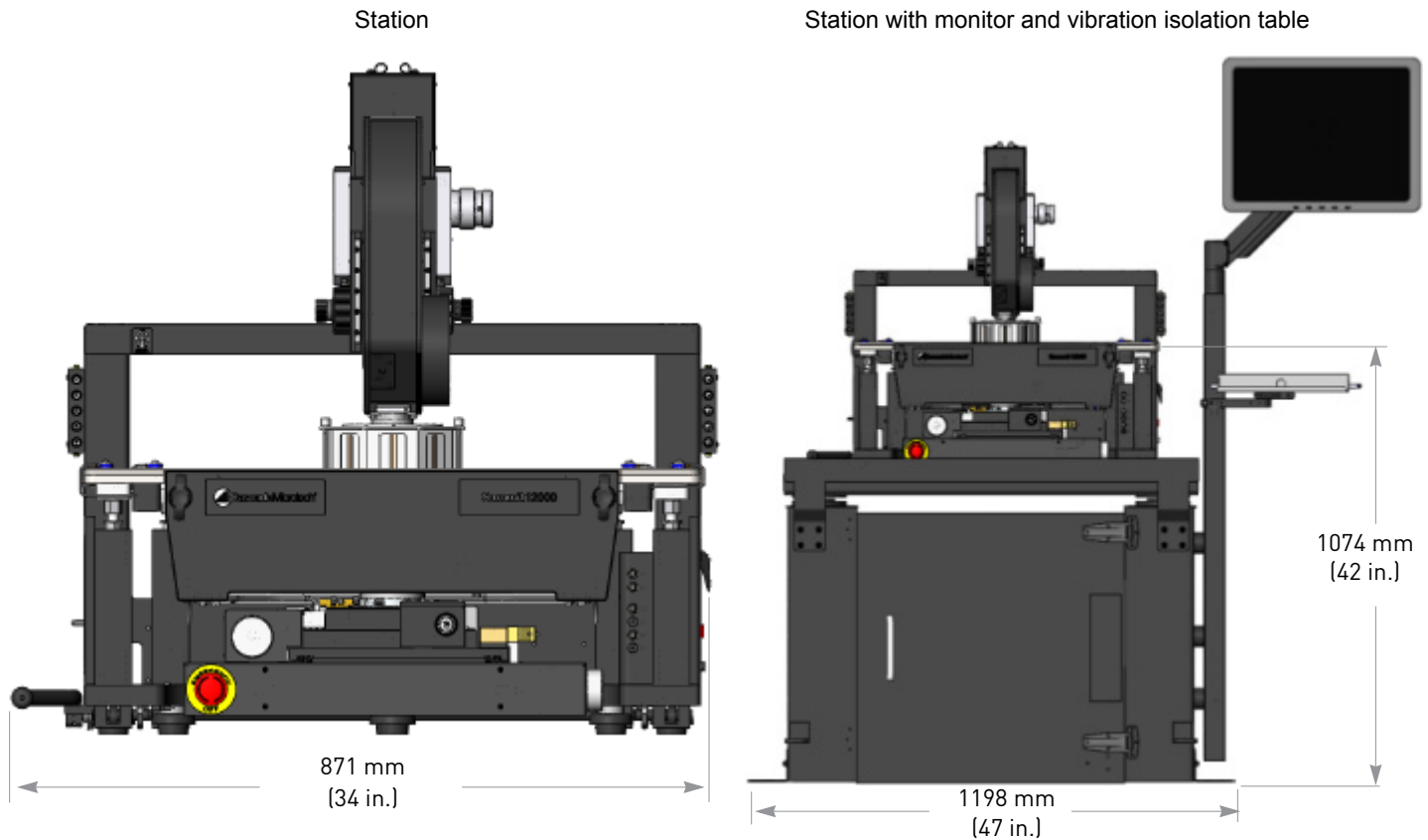

Summit 11000/12000 Probe Station

Side View

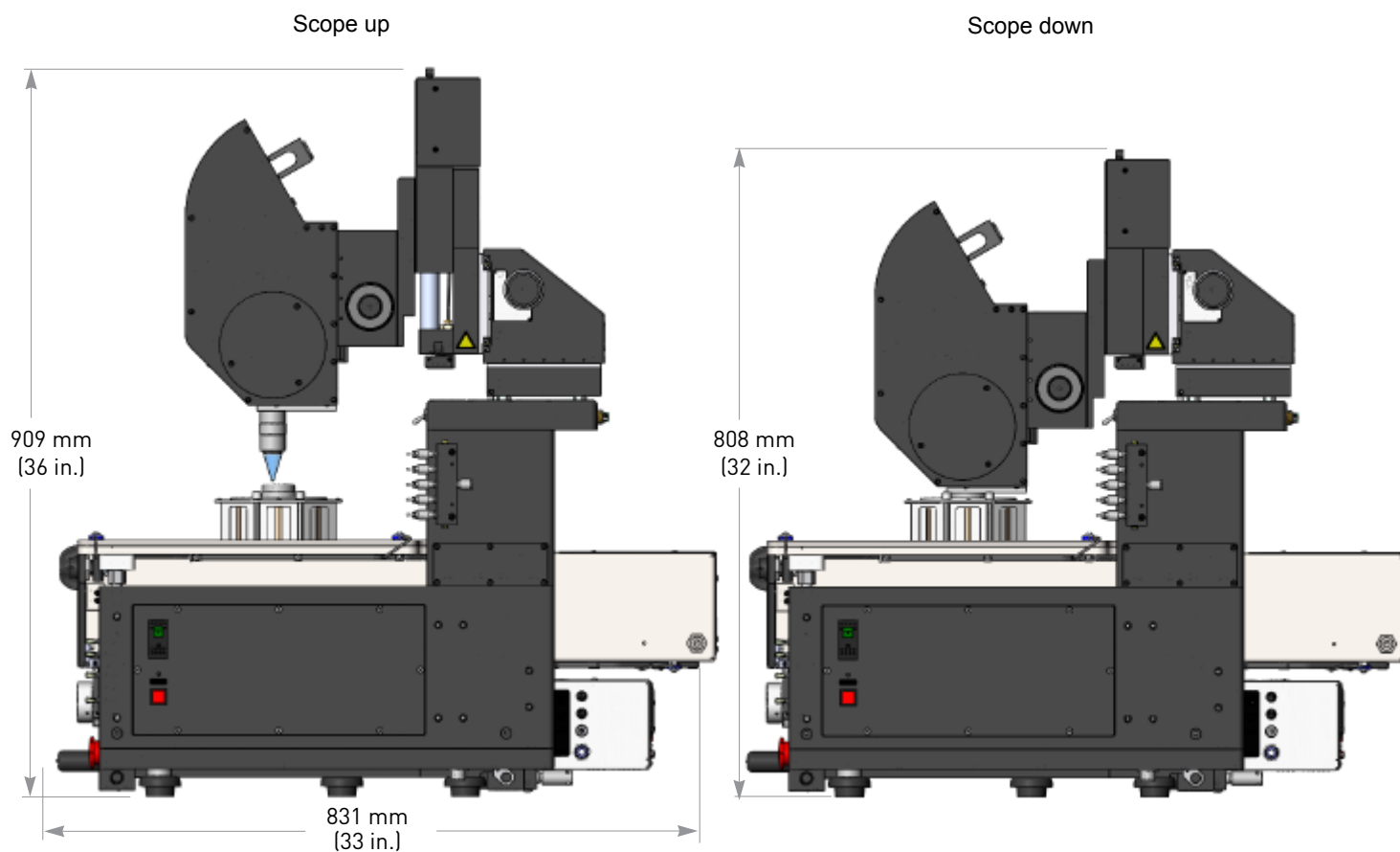

Summit 11000/12000 Probe Station

Station with monitor and vibration isolation table

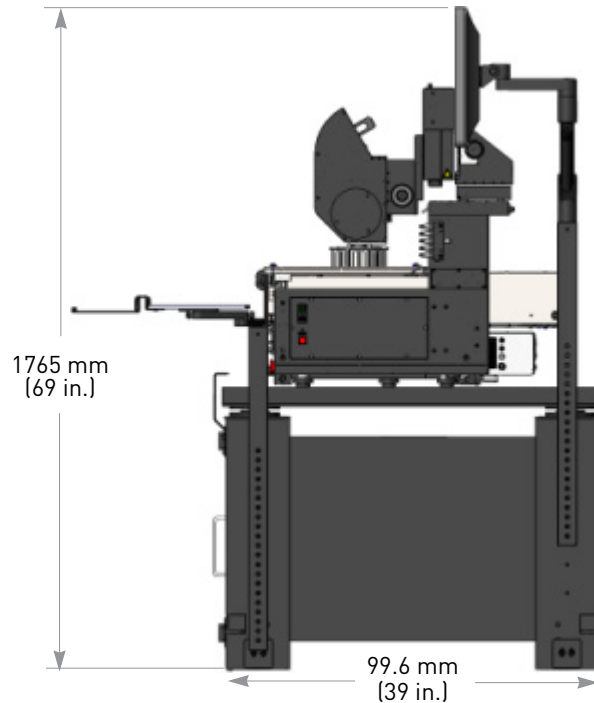

© Copyright 2018 FormFactor, Inc. All rights reserved. No part of this document may be reproduced, transmitted or displayed in any form or by any means except as duly authorized by FormFactor, Inc. FormFactor and the FormFactor logo are trademarks of FormFactor, Inc. All other trademarks are the property of their respective owners.

Important Notice

While the information contained herein is believed to be accurate as of the date hereof, no express or implied representations or warranties are made with respect to its accuracy or completeness. FormFactor, Inc., and its subsidiaries disclaim liability for any inaccuracies or omissions. All information is subject to change without notice.

Users are required to read and follow carefully all safety, compliance and use instructions. Users assume all loss and liability arising from the use of products in any manner not expressly authorized. The conditions and methods of use of products and information referred to herein are the entire responsibility of the user and, to the maximum extent permitted by applicable law, FormFactor, Inc., and its subsidiaries shall not be liable for any damages, losses, costs or expenses arising out of, or related to, the use thereof.

No license, express or implied, by estoppel or otherwise, under any intellectual property right is granted in connection herewith. Users shall take all actions required to avoid intellectual property infringement.

Corporate Headquarters

7005 Southfront Road
Livermore, CA 94551
Phone: 925-290-4000
www.formfactor.com

